



SNOW BLOWER

RURIS

HIMALAYA 602





CONTENT

1. Introduction	3
2. Warnings	4
2.1 Warnings on the machine	4
3. General presentation of the machine	5
4. Safe operation	6
5. Safe operation	7
6. Montage	9
7. Controls and Features	14
8. Handling the snow blower	15
8.1 Before starting the engine	18
8.2 Starting the engine	18
8.3 Snow blower operation	20
9. Maintenance	21
10. Service and adjustment	29
11. Storage	31
12. Technical data	32
13. Declarations of Conformity	33



1. INTRODUCTION

Dear Client!

Thank you for your decision to purchase a RURIS product and for your trust in our company! RURIS has been on the market since 1993 and during all this time it has become a strong brand, which has built its reputation by keeping promises, but also by continuous investments aimed at helping customers with reliable, efficient and quality solutions. We are confident that you will appreciate our product and enjoy its performance for a long time. RURIS does not offer its customers only machines, but complete solutions. An important element in the relationship with the customer is advice both before and after the sale, as RURIS customers have at their disposal a whole network of partner stores and service points.

To enjoy the purchased product, please read the user manual carefully . By following the instructions, you will be guaranteed a long use.

The RURIS company is continuously working on the development of its products and therefore reserves the right to modify, among other things, their form, appearance and performance, without having the obligation to communicate this in advance.

Thank you once again for choosing RURIS products!

Customer information and support:

Phone: **0351.820.105**

e-mail: **info@ruris.ro**

2. WARNINGS

2.1 WARNINGS ON THE MACHINE



WARNING: Hot surface. Do not touch!



Wear eye and ear protection!



Read the instruction manual!



Warning! Careful!



Beware of ricocheting objects!

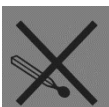

Do not use the machine near fire!



Protect your body from contact with the cutters!



Do not put your hand in the gutter!



Use protective equipment!

3. GENERAL PRESENTATION OF THE MACHINE

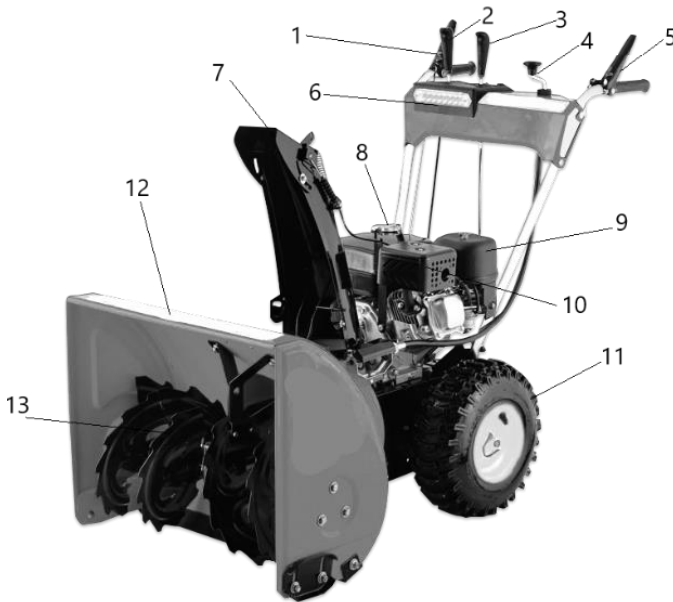

1. Cutter activation lever
2. Travel speed control lever
3. Discharge angle control lever
4. Chute control lever
5. Transmission activation lever
6. lights
7. trough
8. Fuel tank cap
9. The air filter
10. Muffler
11. Transport wheel
12. vat
13. Haircut



4. SAFE OPERATION



DANGER : This machine was built to be operated according to the safety rules in this manual. Lack of equipment, carelessness or error on the part of the operator can lead to serious injury. This machine is capable of endangering your life and throwing objects. Failure to follow safety rules may result in personal injury.



DANGER : The muffler and some components contain or emit chemicals that can cause ailments.



DANGER : This symbol shows the importance of reading the safety instructions, which, if not followed, may endanger personal safety and/or that of others. Read and follow all instructions in this manual before you start using this machine. Failure to follow these instructions may lead to accidents.

Your responsibility: Use of this machine is permitted only to persons who have read, understood and followed the warnings and instructions in this manual and on the machine.

Keep this manual in a safe place for permanent reference.

Familiarize yourself with the snow thrower control panel.

Do not allow children under the age of 14 to use this machine. Children 14 years of age or older must read and understand the operating instructions and safety rules in this manual and must be trained and supervised by their parents.

Do not allow persons to operate this machine without proper instructions.

Throwing objects can cause serious injury. Set the snow throw pattern to avoid throwing objects on roads or in the direction of passers-by.

Keep bystanders, helpers, animals and children at least 20 meters away from the machine while it is on. Stop the machine if someone enters this area.



Carefully inspect the area where the equipment will be used. Remove all foreign objects that could trip you over or be thrown by the cutter.

Wear protective equipment during operation and when making any adjustments or repairs to protect yourself. Thrown objects that ricochet can cause serious injury.

Do not use the equipment if you are not wearing appropriate winter clothing. Avoid loose clothing that can get caught in moving parts. Do not wear jewelry, long scarves, or other loose clothing that can get caught in moving parts. Wear shoes that facilitate your movement and prevent slipping.

Do not attempt to make adjustments while the engine is running.

Allow the engine to warm up before starting to remove snow.

Use only approved fuel containers and be careful when handling it.

Do not use objects that can be sources of ignition near the machine.

Do not feed in a closed room.

Allow the engine to cool for at least 5 minutes before refueling.

Do not store the machine or fuel in a location where there are flames, sparks or hot objects (eg: oven, boiler, clothes dryer, etc.)

Allow the machine to cool for at least 5 minutes before storing.

5. SAFE OPERATION

Do not place hands or feet near rotating parts, cutter housing or discharge chute. Contact with rotating parts can cause serious injury. Always keep the escape routes clean



After hitting a foreign object, stop the engine, disconnect the spark plug, thoroughly inspect the snow thrower for any damage, and repair the damage (if any) before restarting and operating the machine.

When cleaning, repairing or inspecting the machine, stop the engine and make sure that the cutters and all moving parts have stopped. Disconnect the spark plug to prevent accidental starting of the engine.

The control levers shall be easily operated in both directions and shall automatically return to the disengaged position when released.

Do not use the machine while under the influence of alcohol or drugs.

Be careful of slipping when changing direction and when on inclined surfaces.

Do not overload the capacity of the machine by trying to clear the snow very quickly.

Do not operate this machine without good visibility and light. Always watch your feet and hold the handles firmly. Don't run.

Release the tiller lever when moving the machine.

Do not operate the machine at high speed on slippery surfaces.

If the machine starts to vibrate abnormally, stop the engine and disconnect the spark plug. Inspect carefully for any defects. Fix any faults before restarting.

Do not reach into the tub or drain when the machine is running. Always use the cleaning tool provided to unblock the drain chute.

Use only accessories and spare parts approved by the manufacturer. (ex: wheels, cables, etc.).

Never touch a hot engine.

If your situation is not covered in this manual, contact an authorized RURIS service for assistance.



CAREFUL!

- The use of the snowblower is recommended when the snow layer is fresh and loose.
- **DO NOT** use the upper speed gear if the snow cover is large and the cutter does not face the exhaust. The speed must be adapted according to the height of the snow layer. If the blower forces and pushes the snow instead of throwing it, then the friction piece that drives the wheels will wear out prematurely.
- **DO NOT** use the cutter to clear layers of ice formed by melting and refreezing snow that has been deposited for several days, as it will damage the cutters and block the discharge.
- **DO NOT** use the cutter to remove snow that is in an advanced stage of melting, it can block the evacuation.

6. ASSEMBLY

- Mount the lower support of the horns, fixing in the clamping screws.

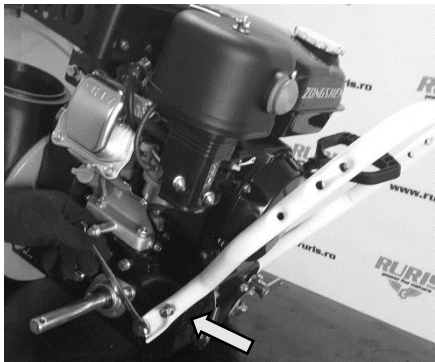

- Mount the wheels, fixing them with the bolts on the axle.



- Mount the upper part of the horns, fixing in the clamping screws.



- Connect the cutter and wheel drive cables.



- Install the exhaust chute, securing it to the mounting screws on the mechanical frame.



- Connect the exhaust chute angle control cable.

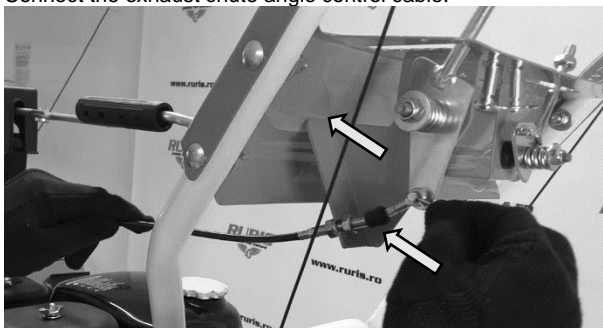

- The shifter rod is connected.



- Mount the control lever handles.

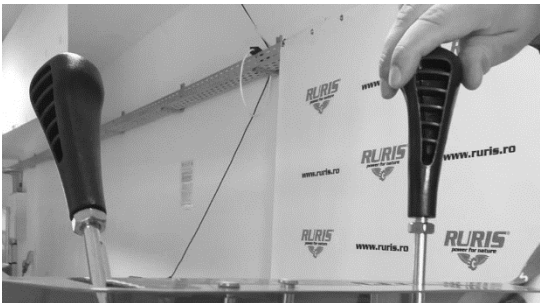

The images are informative, the supplier reserves the right to make structural and functional changes to the machine presented in this manual.



7. CONTROLS AND FEATURES

Snow thrower gear shifter:

R2 R1 1 2 3 4 5 6

Himalaya 602

The gear shifter is positioned between the machine's horns. Place the shifter in any of the (8) positions to control the direction of travel and speed.

Before

There are six forward speeds. Position one is the slowest and position six the fastest.

Back

There are two speeds for going backwards.

Priming pump

Carburetor priming is done by pressing the pump x 3.
(for devices equipped with a pump)

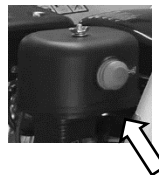

Shock flap (for machines equipped with a flap)

OPENED CLOSED



Activating the choke lever helps start the engine.

Acceleration control

The acceleration control is placed on the engine. It regulates the engine speed .

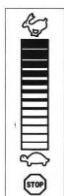

Fast

SLOW

8. HANDLING THE SNOWBLOWER

Cutter control

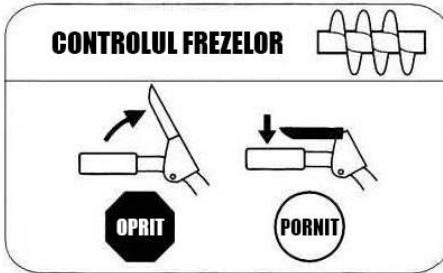

The cutter control lever is located on the right hand grip. Operate the control lever on the handle to start the blades turning and start the snow throwing action. Release to stop.

Steering control

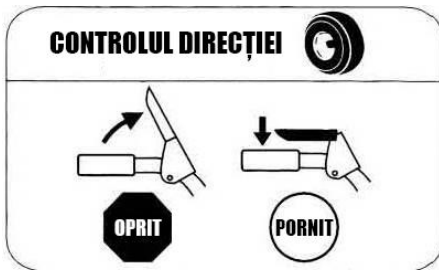

The transmission activation lever is positioned on the left handle. Press the lever to start moving. Release to stop.

Exhaust chute control



Changing the snow throwing direction is done manually from the control handle.

Spin clockwise to throw right

Rotate counterclockwise to throw to the left.

Turn off the engine and stay behind the horns until all components have stopped before cleaning.



The gutter cleaner is attached to the cutter guard at the top with a clamp assembly. The tool is designed to clean the exhaust chute.

Adjustable skates

Position the adjustable skates on the ground surface. Aim the pan up for snow with gravel or small obstacles. Point it down when maneuvering on smooth surfaces.

Haircut

The cutter has the role of cutting the snow, it rotates and throws snow through the discharge chute.

The exhaust chute

Snow drawn into the cutter housing is discharged via the directional discharge chute.

The fuel cap

Open the fuel cap to put fuel in the tank.

Oil supply

Undo the oil cap and fill with oil through the filler hole,

Traction control with the help of the differential

To turn slightly around the axle, operate the differential lever located under the right guide horn of the snowblower.

Actuation is done by suddenly tightening (approaching) the lever on the guide horn. At this moment one wheel is stationary and the other is in motion, which leads to a change in the direction of travel. (Fig. A).

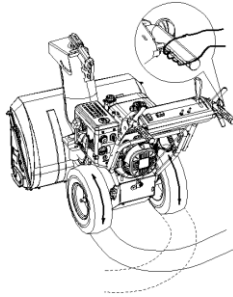

Fig. A

Disengagement is done by suddenly releasing the differential lever from under the guide horn, and at this moment the traction is integral to both wheels, and the snowblower moves forward. (Fig. B).

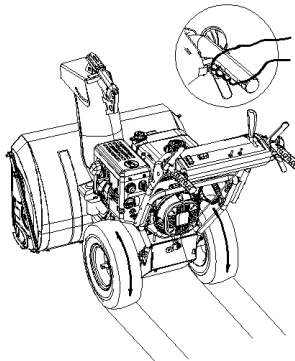

Fig.B

CAREFUL! Before operating the differential lever, completely stop the movement of the wheels, because the differential coupling is done with the wheels stationary (stopped), otherwise you risk destroying the differential coupling.

The differential acts on one wheel.



8.1 BEFORE STARTING THE ENGINE

1. Do not start the engine without the oil level topped up. The engine can be seriously damaged without oil.
2. Place the machine at ground level.
3. Check the oil level using the dipstick provided.
4. Fill with oil up to the HIGH mark.
5. Use only oil recommended by the manufacturer.
6. Use **RURIS** 4T WINTER GT SAE 10W-40 oil.

Combustible

CAUTION: Be careful when handling the fuel, it is highly flammable and the vapors are explosive. Never fuel the machine in an enclosed space, when the engine is running or near flammable objects.

Make sure that the container from which you pour the fuel is clean and free of rust or other impurities.

Load always open the tank and use a funnel to prevent leaks, using unleaded gasoline.

Be sure to wipe off all traces of fuel before starting the engine.

8.2 STARTING THE ENGINE

1. **Starting** Turn the ignition switch to the ON position.
2. Press the priming pump two or three times if the engine is cold to start it, making sure to cover the vent in the center of the pump when you press. (if equipped)
3. Position the choke lever in the CLOSED position (when the engine is cold). (if equipped)

NOTE : If the engine is already warmed up, move the choke lever to the OPEN position.

4. Open the gas valve.
5. Pull the starter gently to the point where you feel tension.



6. Pull the starter firmly steadily, do not release the starter but allow it to return to the starting position. Maintain a firm grip on the starter.
7. While the engine is warming up, gently turn the choke valve to the OPEN position. If the engine is sputtering, turn the choke back to the CLOSE position, and then gently back to the OPEN position. (if equipped)

Key start

1. Turn the power switch to the ON position. (if equipped)
2. Press the priming pump two or three times if the engine is cold to start it, making sure to cover the vent in the center of the pump when you press. (if equipped)
3. Position the choke lever in the CLOSED position (when the engine is cold).
4. **NOTE** : If the engine is already warmed up, move the choke lever to the OPEN position. (if equipped)
5. Open the gas valve.
6. Enter the power key. Make sure it fits and keep the ignition on for about 2 seconds until the engine starts.
7. The engine cannot be started if the key is not fully inserted into the ignition button.
8. While the engine is warming up, gently turn the choke valve to the OPEN position. If the engine is sputtering, turn the choke back to the CLOSE position, and then gently back to the OPEN position. (if equipped)

NOTE : Allow the engine to warm up for a few minutes after starting. The engine will not operate at full power until it reaches the optimum temperature.

Stopping the engine

To stop the engine, turn the switch to the OFF position.

Keep the engine running for a few minutes before turning it off to remove any moisture from the engine.



8.3 SNOWBLOWER OPERATION

To prevent possible engine freezing, proceed as follows:

DISCHARGE GUTTER CLEANING

Hand contact with cutters during operation is the most common form of injury associated with the machine. Never use your hand to clean the drain chute.

To clean the gutter:

1. STOP THE ENGINE!

2. Wait 10 seconds to be sure that the cutter blades have stopped rotating.
3. Always use a cleaning tool, not your hand

The cleaning tool

1. Release the tiller and direction control levers.
2. Turn off the engine
3. Remove the cleaning tool from the clip that secures it.
4. The gutter cleaning tool is positioned on top of the tub with retaining clips. If snow or ice accumulates in the discharge chute assembly during operation, use the tool to clean the chute and its cavity when the snow is no longer discharged.

CAUTION : The muffler, the engine and the area around them get hot and can cause burns. Do not touch.

Reattach the cleaning tool with the retaining clip and start the engine.

While in the operator position (behind the machine), engage the cutter control for a few seconds to clear any remaining snow or ice from the chute assembly.

Setting the direction of travel and the speed.

Place the gear shifter in one of the forward or reverse positions. Select the appropriate speed for the snow conditions and a comfortable pace for you.

NOTE : Use lower speeds until you become familiar with snow thrower operation.

Move the cutter control lever in the ON direction and they will spin. Release it and the cutters will stop.

IMPORTANT : NEVER reposition the direction changer without first releasing the direction control and stopping the snow thrower completely. Doing so will lead to premature wear of the snow thrower's friction system.

9. MAINTENANCE

Caution : Before lubricating, repairing or inspecting, release all controls, stop engine. Wait until all moving parts have stopped completely .

Pinion shaft

The pinion shaft must be lubricated once a season or after every 25 hours of operation.

Remove the bottom cover by removing the two screws that secure it.

Apply a thin layer of universal lubricant to the shaft. (see Fig. 7)

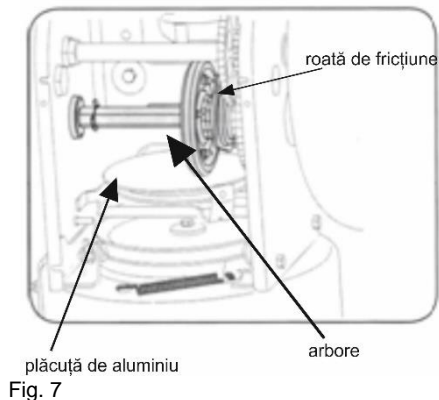

IMPORTANT : Avoid oil leakage on the rubber friction wheel and the aluminum steering plate.

wheels

Remove both wheels at least once a season. Clean and lubricate the axles with an all-purpose automotive lubricant before reinstalling the wheels.

Directional chute control

The control handle should be lubricated once a season with graphite petroleum jelly, linseed oil, mineral oil, clear paraffin or 3-in-1 oil.

Milling spindle

At least once a season, remove the safety pins from the tiller shaft. Apply lubricant inside the spindle around the spacers. Also lubricate the clamps at each end on the shaft. See Fig. 8.

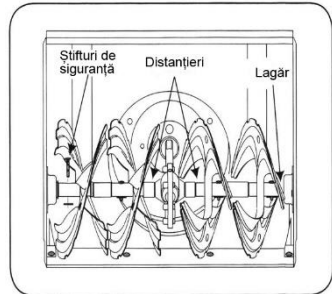

Fig. 8

reducer

The cutter gear was filled with petroleum jelly. Before use, unscrew the power plug and insert approx. 100-150ml of transmission oil. This oil mixed with vaseline ensures more effective lubrication at low temperatures.

NOTE : Do not overcharge the reducer. Failure of the sealing devices may result. Make sure the vent is clear of petroleum jelly so you can release the pressure.

Adjustable cutters and skids.

The blades and adjustable skids at the bottom of the snowblower are subject to wear and tear. They should be checked periodically and replaced when necessary.

Replacing the height adjustment skids

Replace the four lock screws and nuts securing them to the snow thrower.

Reassemble the new skids with the four locking screws (two on each side) and the hex neck nuts. See Fig. 9 .

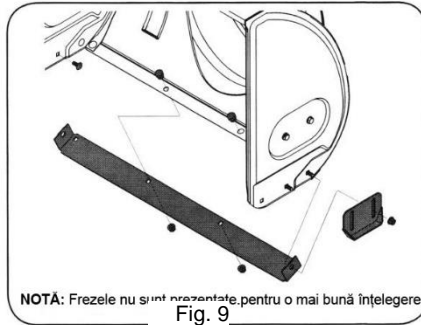

Replacing the cutter drive belt

To remove and replace the snow blower drive belt, proceed as follows:

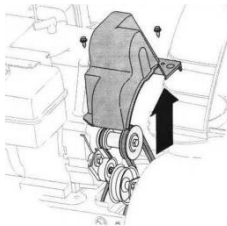
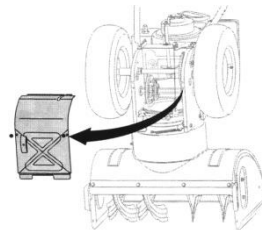

Fig. 10

Remove the belt cover from the front of the engine by removing the two screws. See Fig. 10

Carefully tilt the machine forward to rest on the cutter housing. Remove the cover from the bottom of the machine by removing the 4 sheet metal screws that secure it. See Fig. 11.

Run the cutter drive belt off the motor drive pulley. See Fig. 12.



Unscrew and remove the step screw that secures the strap. See Fig. 11

Unscrew the spring bracket from the housing. See Fig. 13.

Remove the belt from around the cutter drive wheel and insert it between the spring support and the cutter drive wheel. Reassemble the cutter belt by following the instructions in reverse order. See Fig. 14.

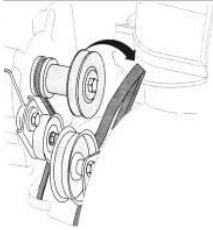

Fig.12

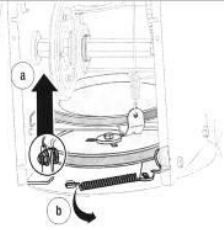

Fig.13

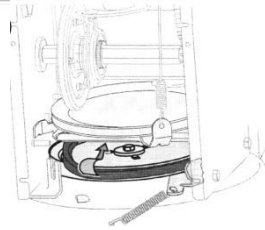

Fig.14

NOTE : Remember to reinstall the step screw and reconnect the spring to the housing after installing a replacement belt.

cutters

- The cutter is attached to the spiral spindle with two safety pins and a cotter pin. If the cutter hits a foreign object or ice build-up, the thrower is designed so that the pins rotate. See Fig. 18.
- If the cutters do not rotate, check that the pins have rotated. When replacing the pins, apply a lubricating oil to the spindle before installing the new pins.

Replacing the drive belt

To remove and replace the cutter belt, proceed as follows:

- Remove the belt cover from the front of the engine by unscrewing the two retaining screws. See Fig. 10.
- Drain the fuel from the machine's tank.
- Remove the case protection from the bottom.
- Undo the screws securing the protection. See Fig. 16.
- Take the wheel by the loose belt and rotate it to the right.
- Run the cutter belt off the motor drive pulley.
- Lift the steering belt off the engine drive wheel. See Fig. 17.
- Slip the steering belt between the friction wheel and its disc. See Fig. 18.
- Remove and replace the belt in reverse order.

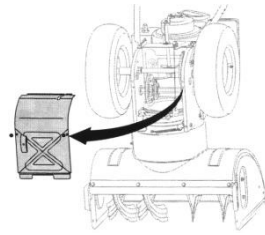

Fig. 16

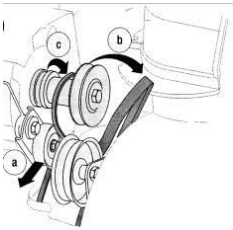

Fig. 17

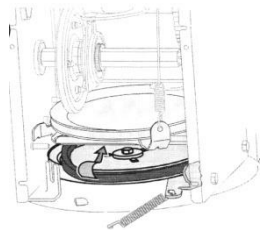

Fig. 18

Removing the friction wheel

If the machine does not operate with the steering lever engaged and adjusting the steering control cable does not correct this problem, the friction wheel may need to be replaced. Follow the instructions below.

Check the friction wheel for wear and replace if necessary.

Move the gear shifter to forward 3 position.

Drain the fuel from the tank.

- a. Remove the housing cover from the bottom of the snow thrower by removing the 4 sheet metal screws.

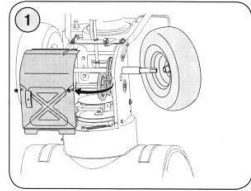

Fig. 19

Remove the right wheel by unscrewing the screw and washer securing it to the shaft. See Fig. 19.

Remove the hex bolt and washer securing the hex shaft to machine housing and gently tap the end of the spindle to remove the ball bearing from the right side of the housing. See Fig. 20.

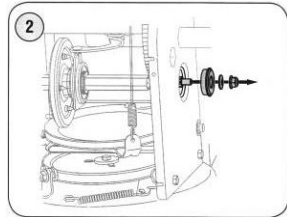

Fig. 20

Position the hex shaft down left before carefully removing the friction wheel assembly from the shaft.

NOTE : If replacing the entire friction wheel assembly, remove the worn part and attach the new part to the hex shaft. Follow the steps above.

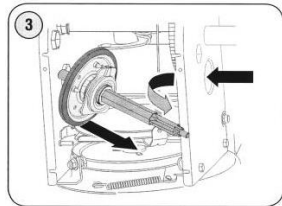

Fig. 21

Proceed as follows. See Fig. 21.

Remove the 4 screws securing the side plates of the friction wheel.

See Fig. 22.

Remove the rubber ring between the plates and reassemble them with a new ring.

NOTE : When reassembling the friction wheel, tighten each bolt only once before turning the wheel clockwise and continuing with the next bolt.

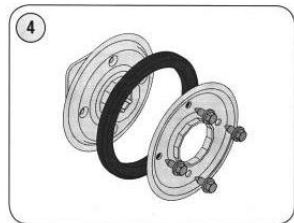

Fig. 22

Repeat the process a few times to secure the plates with equal force.

Attach the friction wheel back to the hex shaft and follow the above steps in reverse order to reassemble the components.

This operation is performed in an authorized RURIS service.

Engine oil check

Unscrew the oil tank cap from the oil supply tube and clean the dipstick. See Fig. 2. 3.

Put the cap back and secure it.

Undo and remove the oil tank cap from the feed tube.

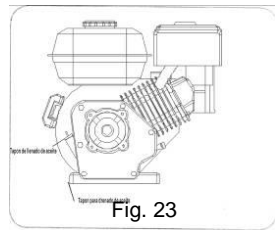

Check the oil level. If the oil level on the dipstick is below the LOW limit, add oil until it reaches the HIGH level. See Fig. 24.

Put the cap back and secure it.

Wipe up any oil spills.

Engine oil change.

To avoid engine wear it is important to:

- Check the oil level before each use and every 5 hours of operation.



Fig. 24

- Change the oil after the first 5 hours of operation and every 25 hours of operation.
- The engine should be warm but not hot after a recent run.
- Make sure the fuel cap is tight.
- Clean the area around the drain plug.
- Place an approved recyclable oil container under the drain plug.
- Remove the cap and drain the oil.

Note : Used oil must be stored in a special container.

Install the drain plug and secure it. Refill the engine with the recommended oil.

The oil capacity of the engine is:

- **Himalaya 602 – 0.6l**

Wipe up any oil spills.

Checking the spark plug

Check the spark plug annually or every 100 hours of operation.

Clean the area around the spark plug.

Remove and inspect the spark plug.

Replace the spark plug if the ceramic part is cracked or if the electrodes show corrosion, burns or deposits.



Fig. 25

Check the gap between the electrodes with a feeler gauge and set the gap to 0.75 mm if necessary. See Fig. 25.

Reattach the spark plug and secure it.

carburettor

If a carburetor adjustment is required, contact an authorized RURIS service. Engine performance should not be affected at altitudes up to 2134 m. For operation at higher altitudes, contact an authorized RURIS service.

Engine speed

CAUTION : DO NOT modify the engine in any way. Altering factory settings may result in unsafe engine operation.

10. SERVICE AND ADJUSTMENT

After a long period of use or when the belts are adjusted or replaced, the control cables should be adjusted as in Fig. 26.

Insert the cable through the spring so that the filament is visible.

Hold the filament and adjust the screw until you get the correct adjustment.

Pull the cable through the spring again. Clamp it to the top of the derailleur and make the same adjustments for both sides.

Adjustments to the exhaust chute

The distance at which the snow is thrown can be adjusted by changing the angle of the discharge chute assembly using the discharge angle control lever.

Adjusting the skates

For short distance snow removal on a smooth surface, raise the skids higher on the cutter housing.

Use a medium or high position when the area to be cleaned is not smooth, such as a cobblestone street. See Fig. 28

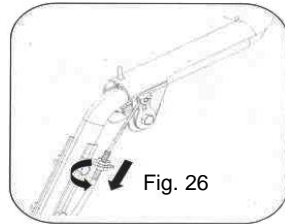

Adjusting the gutter support

If the spiral at the bottom of the chute direction control is not fully engaged with the assembly, its support can be adjusted.

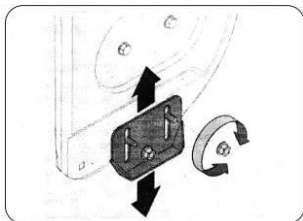

Fig. 28

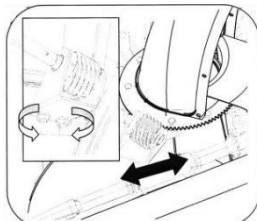

Fig. 29

Tire pressure

Before operation, check the pressure and adjust it between 1.5 and 2.0 bar.

If the pressure is not equal in both tires, the equipment could pull in a direction other than intended.



11. STORAGE

CAUTION : Never store the machine containing fuel in a poorly ventilated room where fuel vapors could reach an open flame, sparks.

NOTE : It is important to prevent deposits from forming on engine fuel system parts such as the carburetor, fuel filter, fuel line, or tank during storage.

The fuel left in the tank for a long period can cause problems at start-up and damage to the carburetor components. Drain all gasoline from the carburetor and tank to prevent deposits on these parts and damage the engine, then run the engine until the tank is empty and stops due to lack of fuel.

Remove the spark plug and pour 30 ml of engine oil through the hole into the cylinder. Cover the spark plug hole with a cloth and run the engine a few times to distribute the oil. Install the spark plug.

Preparing the snowblower

When storing the equipment in an unventilated or metal warehouse, care should be taken to protect the equipment from rust by using an oil or silicone. Lubricate the unit, especially the chains, springs, links and cables.

Remove all dirt from the outside of the unit and motor.

Follow the lubrication instructions in the Maintenance section.

Store in a clean and dry place.

12. TECHNICAL DATA

Motor	Loncin Winter Engine
Operating cycle	4 times
Engine power	7 hp
Cilindrical capacity	212 cc
Oil bath capacity	0.6l
Transmission	Friction disc
Ignition system	Electronic
Starting	Turnkey electrics
Heated handles	Standard equipment
Lighting system	light
Combustible	Unleaded gasoline
Tank capacity	2.2l
Average fuel consumption	1.7l
Work speeds	6 forward + 2 backward
Discharge distance	11 m
Exhaust gutter adjustment	Control panel
Working width	66 cm
Working height	54 cm
Angle of rotation of the exhaust chute	190°
Chute outlet angle	Max. 70 °
Wheel diameter	15x4.80-7
Handle vibrations	6,362 / 5,511 m/s^2
Net weight with accessories	92 kg
Guarantee	24 months

- **SR EN ISO 13849-1:2016/ EN ISO 13849-1:2016**- Machine safety. Security-related parts of control systems. Part 1: General design principles
- **SR EN ISO 13857:2020/ EN ISO 13857:2020**- Machine safety. Safety distances to prevent upper and lower limbs from entering hazardous areas
- **SR EN ISO 14982:2009/ EN 14982:2009** – Agricultural and forestry machines. Electromagnetic compatibility.
- **SR EN 55012:2008/A1:2010/ EN 55012:2007/A1:2009**- Vehicles, boats and internal combustion engines. Characteristics of radioelectric disturbances. Limits and measurement methods for the protection of outdoor receivers
- **SR EN IEC 61000-6-1:2019 / EN 61000-6-1:2019** – Electromagnetic compatibility general standards Immunity for residential, commercial and lightly industrialized environments
 - **Directive 2000/14/EC** (amended by Directive 2005/88/EC) – Noise emissions in the outdoor environment
 - **Directive 2006/42/EC** - regarding machines - placing machines on the market
 - **Direction 2014/30/EU** - on electromagnetic compatibility (HG 487/2016 on electromagnetic compatibility, updated 2019);
 - **EU Regulation 2016/1628 (amended by EU Regulation 2018/989)** - establishing measures to limit gaseous emissions and polluting particles from engines

Other Standards or specifications used:

- **SR EN ISO 9001** - Quality Management System
- **SR EN ISO 14001** - Environmental Management System
- **SR ISO 45001:2018** - Occupational Health and Safety Management System.

MARKING AND LABELING OF ENGINES

Spark ignition gasoline engines received and used on RURIS equipment and machines, according to **EU Regulation 2016/1628 (amended by EU Regulation 2018/989)** and HG 467/2018 are marked with:

- Manufacturer's brand and name: ZKM&E Co.ltd .
- Type: G210FDS
- Type approval number obtained by the specialized manufacturer:
e13*2016/1628*2016/1628TRA1/P*0407*00 ;
- Engine identification number – unique number.
- Concept Loncin

Note: the technical documentation is owned by the manufacturer.

Clarification: This declaration is in accordance with the original.

Validity period: 10 years from the date of approval.

Place and date of issue: **Craiova, 20.06.2023**

Year of application of the CE marking: **2023**

No. reg: **635/ 20.06.2023**

Authorized person and signature:



Ing. Stroe Marius Catalin
Director General of
SC RURIS IMPEX SRL



WARRANTY CERTIFICATE

Certificate series	
Date of sale	
Invoice number	
Product name	
Chassis series	
Country of seller	

For the purchased products, Ruris provides service in the national network, based on the purchase documents*, according to the legislation in force.

*By the notion of "purchase documents", used throughout this guarantee certificate, we will understand the tax invoice and/or tax receipt or the tax invoice and/or tax receipt together with the guarantee certificate.

Important

In order to prevent possible defects that may occur due to improper installation and/or exploitation, we recommend that the commissioning and use instruction of the product be done in a service unit authorized by Ruris. These services can be provided for a fee, depending on the commercial policy of the respective unit, they are not included in the selling price of the product.

Any lack of conformity resulting from an incorrect installation of the products will be considered equivalent to a lack of conformity of the products, if the installation is part of the contract for the sale of the products and the products were installed by the seller or under his responsibility. These provisions also apply if the product intended to be installed by the consumer is installed by him and the incorrect installation is due to a deficiency in the installation instructions, according to art. 7 lit. a) and lit. b) from GEO no. 140/2021.

The services provided by the services authorized by Ruris, which are not part of the sale-purchase contract, are offered for a fee. The list of service units authorized by Ruris is attached to this warranty certificate or can be consulted at: <http://www.ruris.ro/www3/service.html>



I confirm with my signature that I have been trained and received the instructions for use, the instructions regarding labor protection, the method of use and maintenance was presented, the Ruris product was received in perfect working order.

I have read and taken note of the terms and conditions of the warranty, as provided in this Warranty Certificate.

Customer's signature, distributor's signature and stamp

WARRANTY INTERVENTIONS THAT ARE THE OBJECT OF THE WARRANTY

No. crt.	Date of receipt of service	malfunction	Out of service date	The service performed the repair	Signature client	Remarks
1						
2						
3						
4						
5						
6						

Declaration on own responsibility, according to the provisions of GEO no. 140/28.12.2021 regarding certain aspects related to contracts for the sale of goods, shows that the invoiced product corresponds to the manufacturer's execution documentation and national and European standards, according to the test reports issued by specialized laboratories and the manufacturer's certificate of conformity.



According to art. 5 and art. 6 of GEO 140/28.12.2021 products are considered to be compliant if:

- a) comply with the description, type, quantity and quality and have the functionality, compatibility, interoperability and other characteristics provided in the sales contract;
- b) correspond to the special purpose for which the consumer requests them, which the consumer brought to the seller's attention at the latest at the time of concluding the sales contract and which the seller accepted;
- c) are delivered together with all accessories and all instructions, including installation, provided in the sales contract;
- d) are provided with updates according to the provisions of the sales contract;
- e) correspond to the purposes for which goods of the same type would normally be used, taking into account, if applicable, the legal provisions in force, technical standards or, in the absence of such technical standards, codes of conduct applicable in domain and sector specific;
- f) as the case may be, possess the quality and correspond to the description of a sample or model that the seller made available to the consumer before the conclusion of the contract;
- g) if applicable, are delivered together with accessories, including packaging, installation instructions or other instructions that the consumer can reasonably expect to receive; and
- h) respect the quantity and have the qualities and other characteristics, including in terms of durability, functionality, compatibility and security, which are normal for goods of the same type and which the consumer can reasonably expect, considering the nature of the goods and taking into account by any public statement made by the seller or on his behalf or by other persons located in the earlier stages of the chain of transactions, including by the manufacturer especially in advertisements or on the label.

The average duration of use is 5 years, the period during which spare parts are provided under warranty and post-warranty.

For legal entities, the warranty offered for the purchased products is 12 months.

The guarantee for natural persons is 24 months, conditional on the use of the product for the purpose for which it was designed and made, as well as the maintenance of the product according to the maintenance schedule.

The spare parts, accumulators, batteries that equip the products benefit from a 24-month warranty period, in compliance with the conditions of use provided in the user manual.



The installation of spare parts, accumulators and/or batteries that require installation must be done by authorized persons in Ruris services, the performance of these operations by unauthorized persons leads to the loss of the warranty.

The warranty period starts from the moment the product is sold to the end customer, which will be indicated later, upon the warranty request, through the purchase documents.

The guarantee is provided by any service unit authorized by RURIS.

The customer can request warranty repair based on the purchase documents.

The defective product will be brought to the service unit authorized by RURIS and repaired within a maximum of 15 calendar days from the date on which the buyer handed over the product to the seller or to the person designated by him on the basis of a handover-pickup document.

The warranty period is extended by the time elapsed from the receipt of the defective product in the service authorized by Ruris until the date of its return to working condition. For the replaced product, a new warranty period runs from the date of replacement. The extension is registered in the warranty certificate by the service unit authorized by Ruris.

NO WARRANTY IS GIVEN IN THE FOLLOWING SITUATIONS :

- Failure to present the warranty certificate, tax invoice and/or tax receipt
- Existence of defects generated by user negligence, wrong handling, etc
- Use of inappropriate fuel/oil or stored in inappropriate conditions
- Defects generated by user errors regarding the installation or maintenance of the product
- Repairs performed by persons not authorized by Ruris, changes to the original condition of the product
- Using the products for purposes other than those for which they were designed
- The use of accessories or spare parts other than those recommended by the manufacturer.

CAREFUL!

1. Any modification to the initial state of the machine, modifications such as, but not limited to, welding, soldering, cutting the power cable with the plug, unauthorized interventions in the electrical connections, removing guards or canceling the mechanical safety systems, leads to the loss of the warranty. or electrical)

2. **The warranty does not apply to products that show interventions** such as: knocks, cracks, chips, burnt or cracked components/parts, the use of inappropriate supply voltages, subject to large variations in temperature and pressure, mechanical shocks, incorrect handling, the use/ storing products in conditions of humidity, dust, noxious or under the action of chemical substances, etc., incorrect settings and/or installations, faulty sources, sockets without grounding, penetration of liquids, metals and/or other substances inside the equipment, mechanical or plastic intervention on the products, connecting or disconnecting certain components during the operation of the equipment, etc.

THE FOLLOWING COMPONENTS ARE NOT WARRANTED:



- the warranty does not extend to consumables that break down or wear naturally as a result of normal use of the product.

- parts made of PVC, ebonite, rubber, tires damaged due to improper use and/or handling of the product or subject to natural wear of the product are not included in the warranty.

Detailed description of the components that are not covered by the warranty - parts, accessories or subassemblies from:

I. Thermal engine

1. Engine oil, oil filters, air filters, fuel filters, supply hoses, oil seals, rubber rings, elements that are part of the category of consumables whose wear or clogging occurs as a result of normal use of the product.

2. Segments, cylinder, piston, connecting rod, intake valves, exhaust, valve guides, if these parts break down as a result of using the engine with a counterfeit, clogged air filter or without an air filter or other defects caused by using the engine without enough oil or using an engine oil of lower quality than that recommended by the engine manufacturer.

3. The use of a low-quality fuel that leads to the operation of the engine with detonations, with water and/or impurities that lead to the blocking of the fuel system, the carburetor, the injection pump and the injectors.

4. Spark plugs, spark plug plugs, cables, terminals, electrical contacts, if these parts suffer natural wear resulting from normal use of the product, if they are damaged as a result of incorrect handling of the product or if spark plugs other than those recommended by the engine manufacturer are used .

5. Starter handle, starter rope, drive ratchet, return springs, starter roller, starter housing, naturally worn due to normal use of the product or damaged due to wrong handling.

6. Clutches, ferrodu, pressure plates, springs, elements subject to natural wear as a result of normal use of the product or prematurely worn due to improper handling and/or maintenance.

7. Springs, levers, cables that are used to control acceleration and clutch, elements subject to natural wear and tear or damaged due to improper handling and/or maintenance.

II. Mowing table

1. Teeth, rivets, mowing blade, blade guards, adjustment screws, support plates, elements that are part of the category of consumables, if they are subject to natural wear under the conditions of normal use of the product or damaged prematurely as a result of improper use and maintenance.

2. Blade, cleaning plate, spacer rod, blade horseshoe, bar as a whole, elements that are part of the category of consumables, if they are subject to natural wear under the conditions of normal use of the product or damaged prematurely as a result of improper use and/or maintenance.

III. Transmission mechanisms

1. Blade support arm, blade roller, internal crank, external crank, needle bearings, safety caps, sliding cylinder, cardan fork, transmission and distribution belts, rail-cutting gaskets, chains, knives, auocut, transmission belt, elements that they are part of the category of consumables, if they are subject to natural wear and tear under the conditions of normal use of the product or damaged



prematurely as a result of improper use and/or maintenance.

IV. Gearbox

1. Pinions, in general if it is found that there was no oil in the gearbox or if the clutch was not used when changing gears, connecting accessories or operating the reverser.

V. Electrically operated products

1. Bushes, bearing, rotor if they are subject to wear and tear caused by unjustified intensive/excessive use.

2. Collector brushes, elements that are part of the category of consumables, if they are subject to natural wear under the conditions of normal use of the product.

3. Flywheel drive pinion (bendix.) if they are subject to wear and tear, in case of unjustified intensive use.

4. Knives, hammers, collector brushes, shock absorbers, switches, power cable, fuses, valves, solenoid valves, gaskets, consumables that are subject to natural wear and tear during the normal operation of the product or if they are subject to damage caused by improper handling, maintenance and/or exploitation .

VI. Submersible pumps, hydrophores, motor pumps:

The turbine-type (closed or open) and screw-type (snail/sneek) rotors are made of bronze, steel, and rubber, respectively, being subject to wear in different ways, depending on the hardness of the water, but also on the impurities in the water (sand, mud, etc.). For this reason, these components are considered consumables and are not covered by the warranty.

IT IS RECOMMENDED TO THE CLIENT:

1. For 2-stroke engines, a Ruris 2TT Max blend oil (API TC classification) will be used, at the manufacturer's recommendation, or an oil intended for 2-stroke engines with a higher or at least equal classification.

2. For 4-stroke engines, a Ruris 4T Max oil (API classification - CI-4/SL) will be used, at the manufacturer's recommendation, or an oil intended for 4-stroke engines with a higher or at least equal classification.

3. For the gearbox, the Ruris G-Tronic oil (API-GL-4 classification) recommended by the manufacturer or a transmission oil with characteristics and a higher or at least equal classification will be used.

4. To lubricate the chain, use Ruris M-Power oil (L150) or X-Guard oil, recommended by the manufacturer, or an oil for lubrication of circular friction/lubrication mechanisms with characteristics and a superior or at least equal classification.

5. For the protection of piston engines for compressors, the Ruris Compressor Protect oil (K150), recommended by the manufacturer, or an oil for the lubrication of hydrostatic systems and circular friction/lubrication mechanisms with characteristics and a superior or at least equal classification, will be used.

6. For engine lubrication at temperatures up to -25°C, Ruris 4T-Winter GT oil (API classification -CI-4/SL) will be used, recommended by the manufacturer for gasoline or diesel engines or an oil for engine lubrication with characteristics and a higher or at least equal classification.

7. For greasing all categories of reducers, transmissions and gears, Ruris Super Vaseline, recommended by the manufacturer, or any type of vaseline with characteristics and a superior or at least equal classification, will be used.



8. Trailer 450 kg, Trailer 550 kg, Trailer 750 kg, Trailer Ruris 451XL, Trailer Ruris 551XL and the towed accessory Navigator 88/Navigator 99 are not approved and equipped to drive on public roads or on a slope/ramp with a greater inclination of 10 degrees.

9. To extend the life of the purchased products and to optimize their operation, Ruris recommends periodic revisions at 60 days, 6 months, 12 months from the date of purchase. During the revision, operations are carried out such as: checking the general condition of the product (integrity and cleanliness); checking the air filter; checking the state of the spark plug; checking the engine speed; checking couplings.

The Customer will deliver the defective products to the Seller's service and/or collection units specified in the Warranty Certificate or accessible in updated form at the address:

<http://www.ruris.ro/www3/service.html>.

The seller's service and/or collection unit, according to GEO no. 140/28.12.2021, has the obligation to bring the product into compliance within a maximum of 15 days from the delivery of the product, recorded in writing.

The manufacturer and the seller are responsible for the conformity and warranty of the products according to OG no. 21/21.08.1992 regarding consumer protection, republished, as well as according to GEO no. 140/28.12.2021 regarding certain aspects related to contracts for the sale of goods.